

Summer Show 2023

Design Brief for Club tutors

Context

The National Saturday Club annual Summer Show will take place at Somerset House from 15–18 July 2023 with Club member Private Views and Graduation Ceremonies taking place on Saturday 15 and Sunday 16 July

It will be the biggest Summer Show to date with over 90 Clubs taking part across seven Club subjects!

To ensure every Club is celebrated, and that we achieve a sustainable approach to exhibition design, we have developed a new design brief for Club Tutors in partnership with exhibition designers D–P–Q.

We ask that you read the following brief carefully so that we can best present your Club members' work.

The text "Design Brief" is centered within a graphic element consisting of three overlapping, horizontal brushstrokes in a light orange color. The strokes are layered, with the top one being the most prominent and the bottom one being the least. The edges of the strokes are irregular and feathered, giving it a hand-drawn, artistic feel.

Design Brief

Every Club should submit:

- One collaborative piece that involves all Club members
- Designed to fit new display types
A, B, C or D

Additional considerations

Every Club member should contribute to your Club's final piece in some way to ensure they feel represented in the exhibition

All work should be delivered assembled and ready for display

All work should be suitable for viewing by 13–16-year-olds

Display Types

A - Wall display

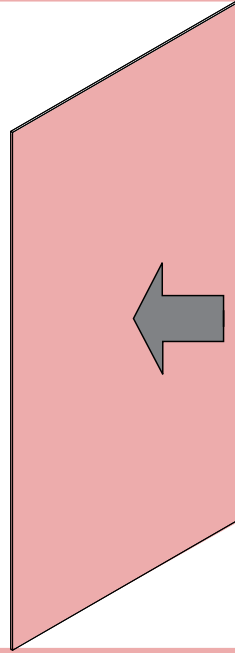

B - Table/ Plinth/ Floor

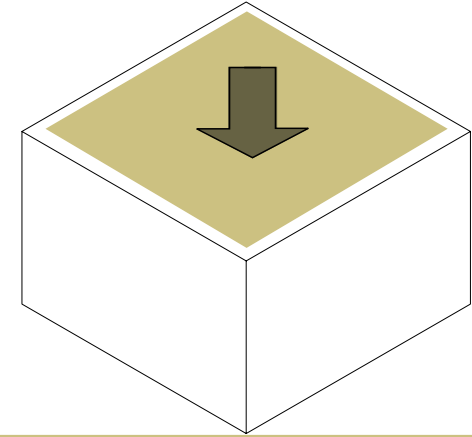

C - Suspended



D - Digital file



Digital display only available for Film&Media and Writing&Talking Clubs

Display Type A

Requirements

- 3D piece of work
- Made from lightweight materials such as paper, card or textiles
- Maximum dimensions as shown
- Fixed with pins, velcro tabs or adhesive

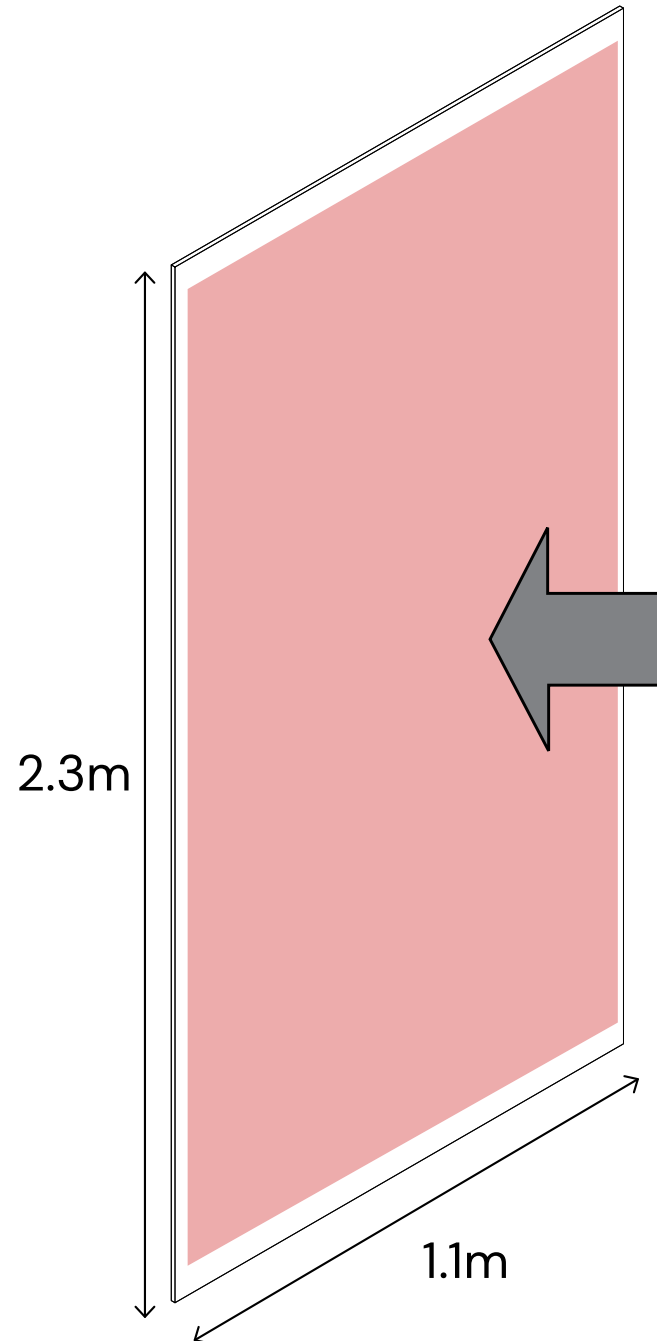

Please provide:

- 1 original piece of work fixed directly onto display board ✓

DO NOT provide

- Multiple individual pieces i.e. 12 paintings that each need their own fixings ✗



Painted tiles created by individual Club members working in collaboration with an artist. This was brought together as a complete wall-based installation.



Club members' collective responses to the provocation 'what is art' were combined on textile panel.

Display Type B

Requirements

- Table/ Shelf/ Plinth/ floor based work
- Weight – can take denser materials, but please confirm weight
- Maximum dimensions as shown
- Can be shown on table or

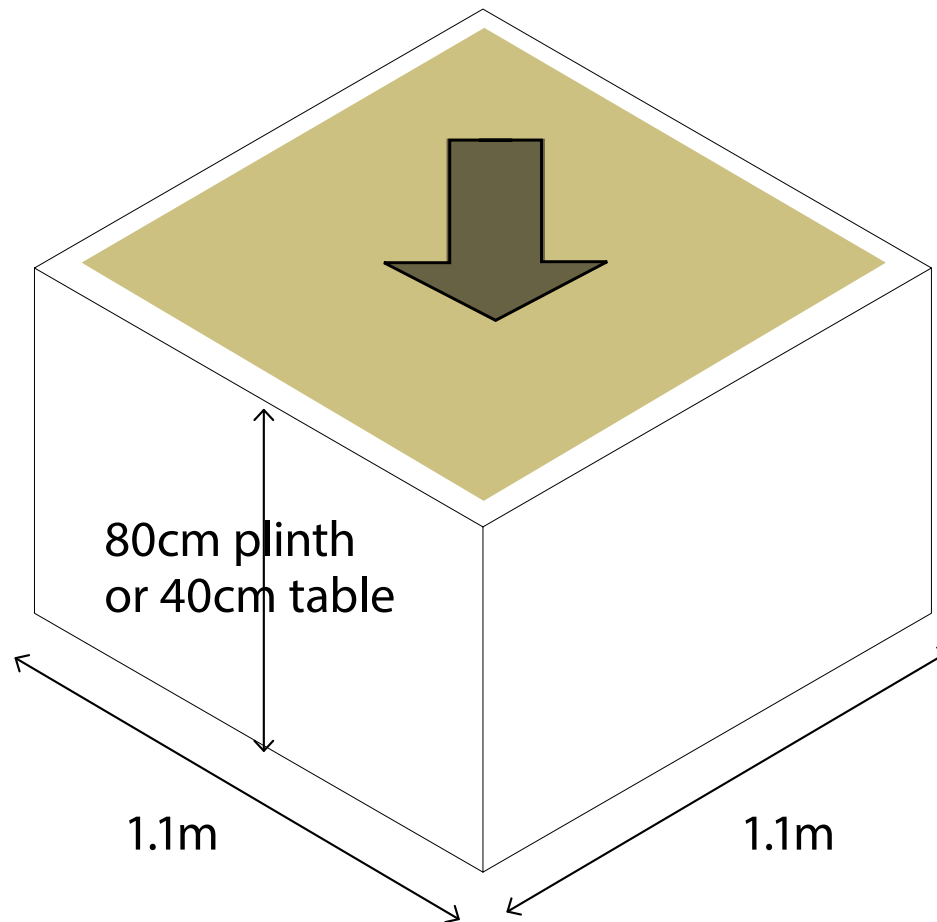

Please provide:

- Original piece of work placed on structure i.e. An architectural model preassembled ✓

DO NOT provide

- Multiple individual pieces i.e. A house of cards that requires stacking ✗



Club members worked together to create a tent installation to raise awareness of important issues such as climate change.



'The town we would like to live in' was a collaboratively built table-top townscape model.

Display Type B - Examples from previous years

Display Type C

Requirements

- Suspended work
- Max weight 5kg
- Maximum dimensions as shown

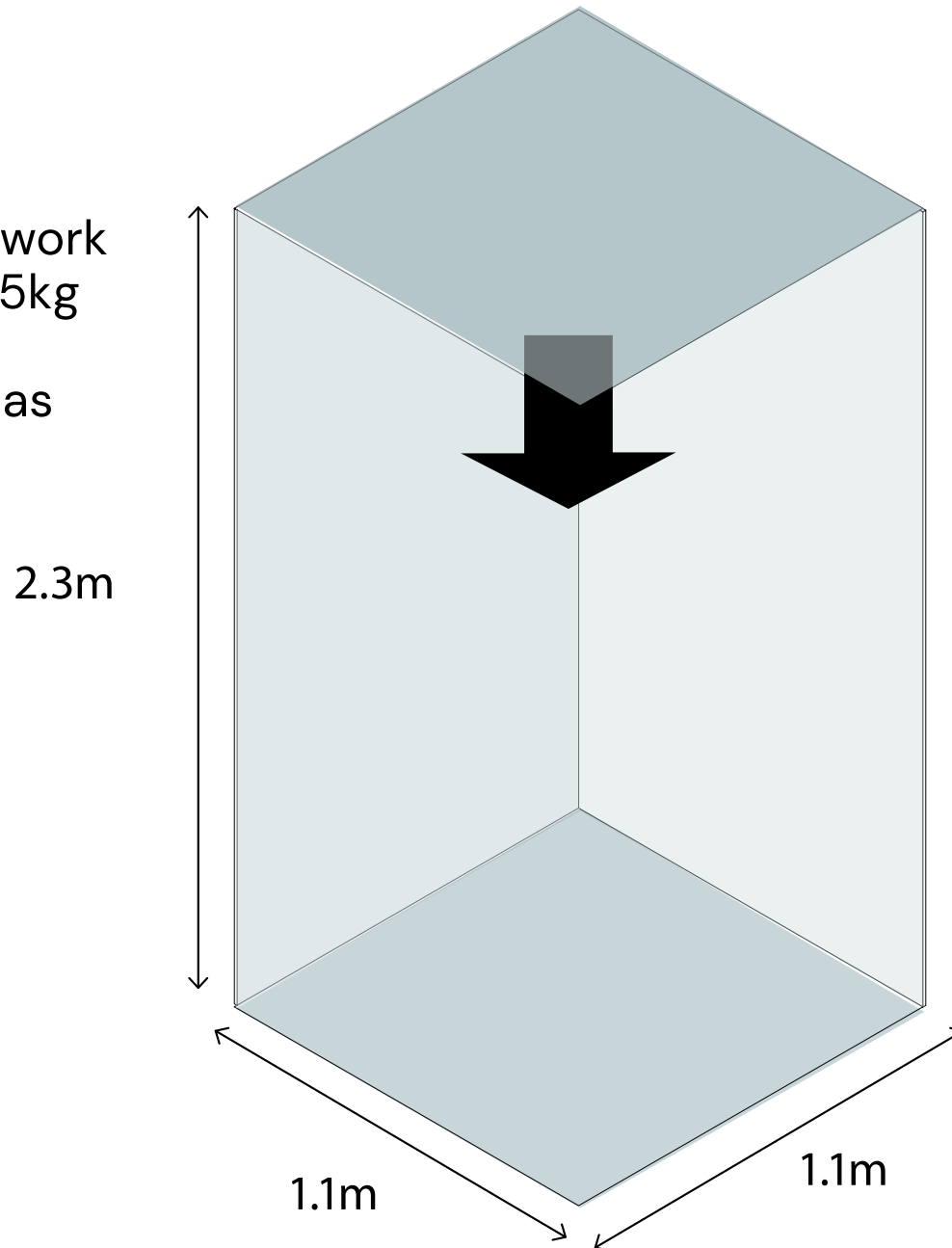

Please provide:

- Original piece of work hung from structure i.e. an item of clothing, tapestry etc. ✓

DO NOT provide

- Multiple individual pieces i.e. 30 bags all needing their own fixings ✗



Kimono was a piece that represented the Club as a collective and was assembled from multiple panels made by each Club member's photogram print.



A mannequin presenting a final cohesive piece with various elements of the outfit created by different Club members.

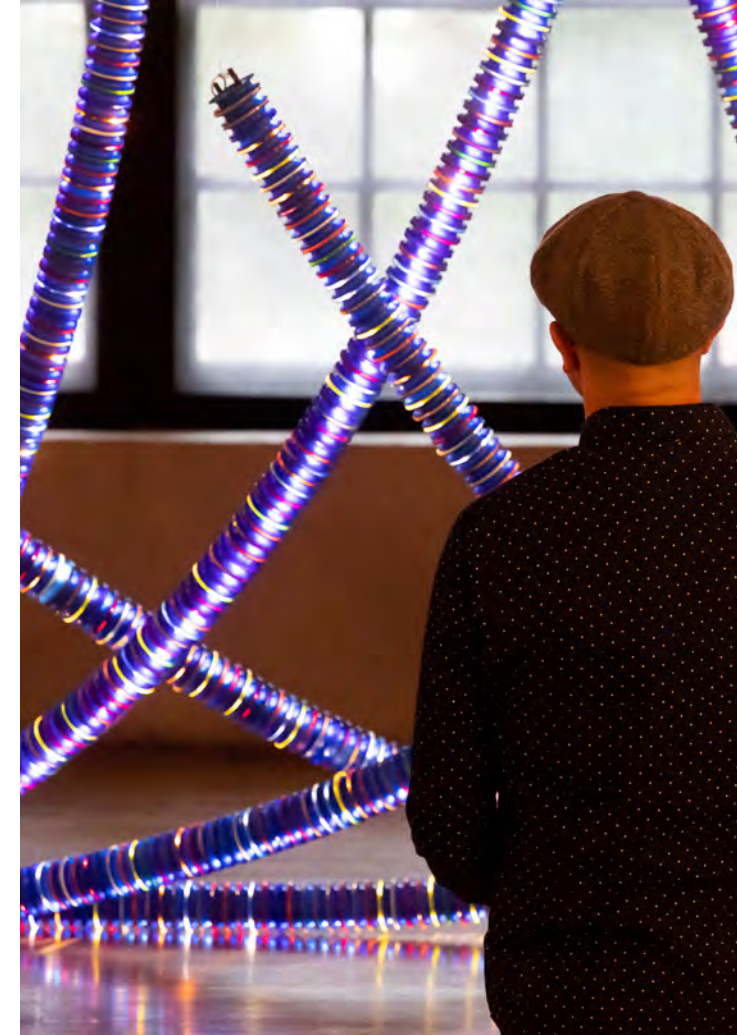

Suspended lighting installation with individual sections made by Club members and brought together to make a whole.

Display Type D – Film&Media and Writing&Talking Only

Requirements

- Digital Work
- Fully edited reel/soundtrack that is maximum 10 minutes long

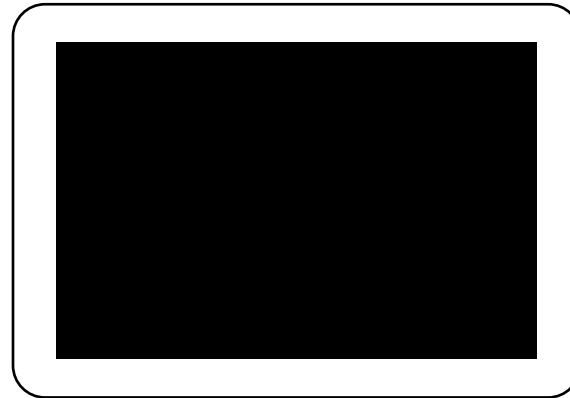

Please provide:

- Video or audio pieces i.e. a podcast or short film ✓
- Max 10 mins

DO NOT provide

- Interactive digital works i.e. a website ✗
- Work requiring a projector



Films that Club members had made were presented as a fully edited showreel using audio visual equipment in the exhibition.

Dates and Logistics

- Please deliver or post the work to Somerset House between 5–6 July and arrange collection on 20–21 July
- All arrangements for delivery and collection will need to be organised by your Club

Online Summer Show

Submissions for the Online Summer Show

Every Saturday Club will also be represented in the National Saturday Club online Summer Show which forms a permanent digital legacy of your Club's programme and activities.

[Click here](#) to see last year's Online Summer Show

You will need to submit one Club project for inclusion in the online gallery with each Club member's work shared as a digital file by Friday 28 April.

We will share a submission form early next year but please note that suitable file types include:
Image = minimum 300dpi, portrait or landscape, jpeg or png. Video = 720p, mp4 or mov.

A reminder about Club members' self-portraits

Club members' self-portraits will also be displayed
at the Summer Show

If you have not yet sent a self-portrait for each of your
Club members please send these digitally to
dhiyandra@saturday-club.org
by Friday 28 April

Next Steps

1. Look over the brief and plan your Summer Show submissions in line with the guidelines
2. Check the guidance on your chosen display type to ensure your submission will be compliant
3. Submit your forms and upload your Club work to your Club Shared Folder – [click here](#) for FAQs

For more information please contact:
programmes@saturday-club.org

Thank you